

## NTE/CCD Vacuum Repumping Procedure

### Introduction

The NTE/CCD Detector is pumped to a high vacuum (on the order of  $10^{-6}$  Torr) before being shipped to assure proper cooling performance and to prevent condensation from collecting on the CCD. In time, the vacuum level could deteriorate to where cooling performance is adversely affected. Even though the detector will still meet its temperature specifications, you may wish to restore the vacuum to maintain the highest possible cooling performance.

**Note:** The NTE camera cannot be successfully repumped unless your vacuum pump is capable of achieving absolute pressures below  $10^{-6}$  Torr. *If your pump can't achieve that level of vacuum, do NOT attempt to repump your NTE camera. Contact the factory for advice.*

A 1/4" Vacuum Pumping fitting (Figure 1) is supplied in the detector accessory kit but is not factory installed. The vacuum access port is located on the left side of the detector beneath the side cover as viewed from the back. See **Preliminary Steps** on following page for detailed access and location information.

Figure 1. The Vacuum pumping fitting.

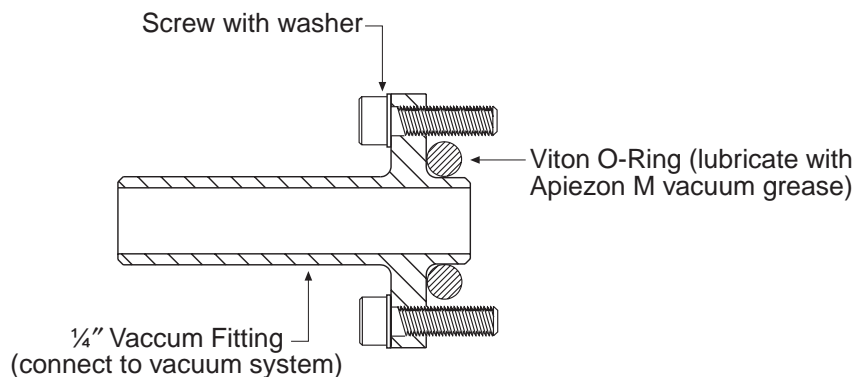

A special indium-tipped Vacuum Seal (Figure 2) is installed in the top of the detector. The Vacuum Seal's indium tip is crushed to provide a metal-to-metal seal in the vacuum chamber when the detector is manufactured. The number of times this can be done before a new Vacuum Seal is required is limited. Typically, an indium tip can be crushed up to ten times before the Vacuum Seal must be replaced to assure a good vacuum seal. Because the tip is crushed only once at the factory, it can be successfully used again numerous times in the field. With repeated repumpings, however, it will eventually be necessary to replace the indium-tipped Vacuum Seal (PI #2550-0352).

**Note:** The required seating torque for successful vacuum sealing is 30-40 in. lb. (3.5-5Nm).

Figure 2.  
Indium-tipped  
vacuum valve.

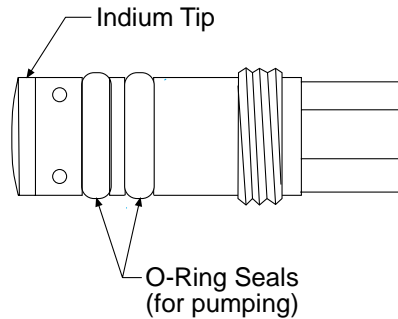

## Requirements

- Laboratory pump capable of achieving absolute pressures below  $10^{-6}$  Torr.

**Note:** The NTE camera cannot be successfully repumped unless your vacuum pump is capable of achieving absolute pressures below  $10^{-6}$  Torr. *If your pump can't achieve that level of vacuum, do NOT attempt to repump your NTE camera. Contact the factory for advice.*

### CAUTION

Your vacuum system *must* have a trap (ideally cryogenic) placed between the detector and the pump to prevent contamination due to oil backstreaming from the pump.

- An environmental chamber able to house the detector during pumpdown and maintain it at a temperature in the range of 40°C to 50°C for 48 hr.

**Note:** The heated chamber is not required, but its use will extend the time before the detector has to be repumped.

- 5/16" hex torque wrench for tightening the indium-tipped Vacuum Seal.
- 3/32" hex key (Allen wrench) for removing the back-panel screws.
- 3/16" nut driver for removing the screws that secure the Controller interface connector to the back panel.
- A new Indium-tipped Vacuum Seal, PI #2550-0352. A new seal will only be required if the detector has been repumped a number of times and the original seal is no longer able to maintain vacuum.

## Procedure

### WARNING

Wait at least two hours after the detector was last operated before proceeding. This is necessary so that the CCD can warm to ambient before being opened to the atmosphere. If opened when still cold, potentially harmful condensation could form on the CCD.

### Preliminary Steps

- ◆ Turn off the system power and disconnect all cables.

- ▶ Remove the four screws that secure the back panel (Figure 3).
- ▶ Remove the two screws that secure the Controller interface connector to the back panel (Figure 3). *Figure 4 shows the back panel with all of the screws removed.*

Figure 3. Back Cover.

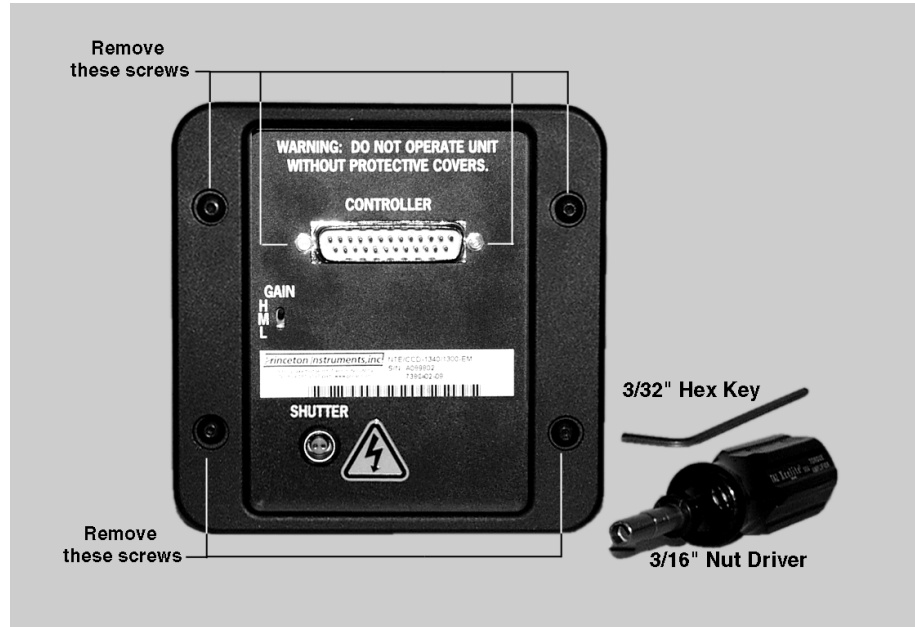

Figure 4. Back panel with screws removed.



- ▶ Grasp the back panel firmly and pull it free of the camera (Figure 5).
- ▶ Grasp the top cover firmly and pull it free of the camera. Similarly remove the bottom cover. Figure 6 shows the camera with the covers removed and indicates the

location of the Indium tipped Vacuum Seal and mounting holes for the Vacuum Pumping Fitting.

*Figure 5.  
Camera with  
back panel  
removed.*

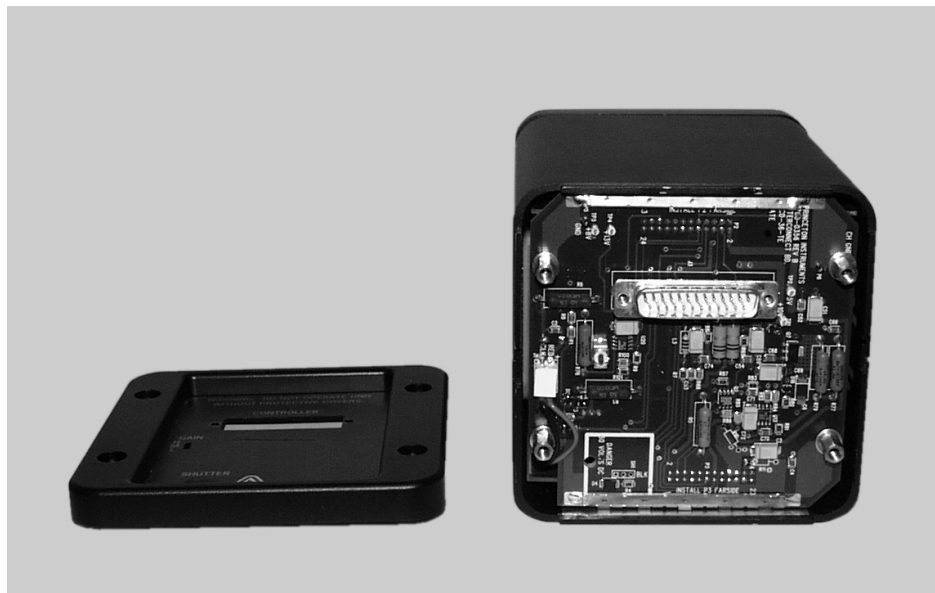

*Figure 6.  
Location of  
Indium Tipped  
Vacuum Seal  
and mounting  
holes for  
Vacuum  
Pumping  
Fitting.*

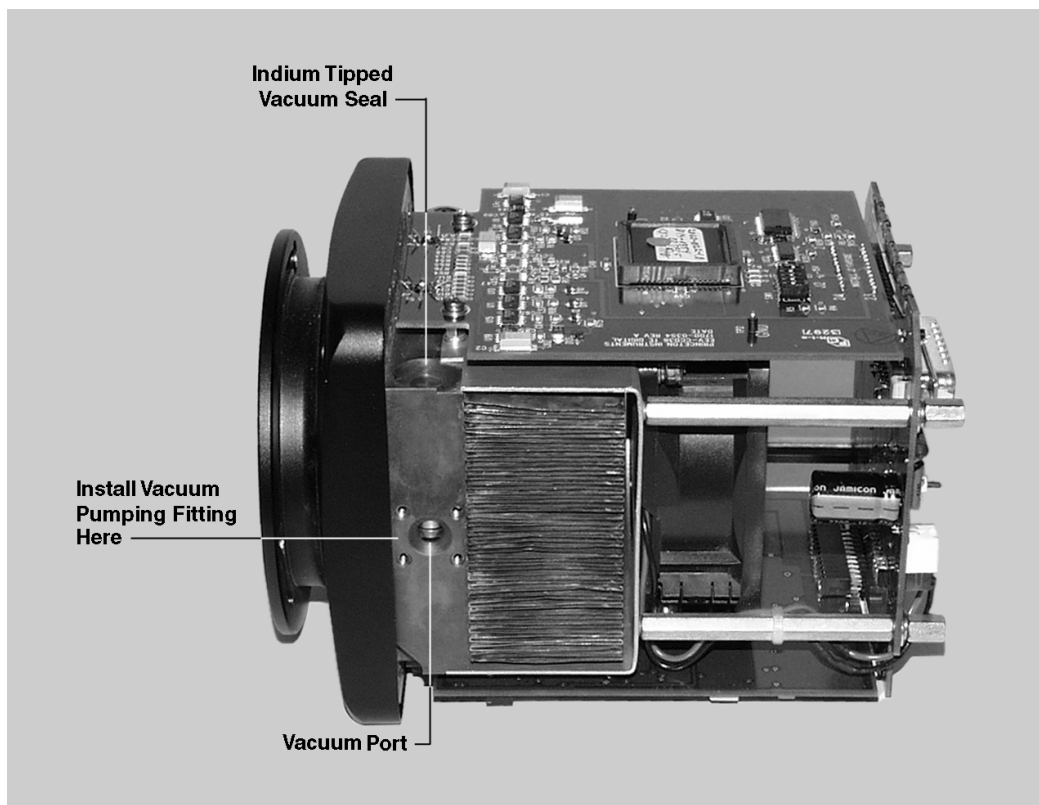

- ▶ If an environmental chamber is to be used, place the detector in the chamber. A 48 hr bakeout is recommended during the pumpdown procedure.

- ◆ **Note:** Again, the heated chamber is not required, but its use will extend the time before the detector has to be repumped.
- ◆ Apply a light coating of high-quality vacuum grease such as Apiezon M to the O-ring on the Vacuum Pumping Fitting supplied with the system.
- ◆ Remove the cap from the vacuum access port at the side of the detector. *A cap may not be present.*
- ◆ Mount the Vacuum Pumping Fitting to the vacuum port and secure it with the four screws provided. *The screws only need to be snug; do not overtighten. While pumping, the vacuum seal is made by the greased O-ring and does not depend on the tightness of the flange.*
- ◆ Connect the vacuum hose from the pump to the ¼" fitting at the end of the Vacuum Pumping fitting and clamp the hose connection securely.
- ◆ ***If you are going to reuse the currently installed indium-tipped Vacuum Seal***, turn on the vacuum pump. Then:
  - Using the 5/16" hex torque wrench, rotate the indium-tipped Vacuum Seal two full revolutions counterclockwise, *just enough* to unseal the vacuum.
  - Perform the steps outlined in the Pumping Procedure below.
- ◆ ***If you are going to install a new indium-tipped Vacuum Seal***, do not turn on the pump. Instead perform the steps outlined in the section titled Installing a New Vacuum Seal, which follows the Pumping Procedure.

## Pumping Procedure

- ◆ If using a heated chamber, slowly warm it to a temperature in the range of 40°C to 50°C.
  - ◆ Continue pumping for 24 hr. The final vacuum should be below  $10^{-6}$  Torr.
  - ◆ When the required vacuum level has been achieved, ***slowly*** tighten down the indium-tipped Vacuum Seal with the 5/16" torque wrench to crush the indium tip and reseal the vacuum. (A sealing torque of 30-40 in. lb. or 3.5-5 Nm is required).
- Note:** The reason the indium-tipped Vacuum Seal must be tightened ***slowly*** is to minimize break-away friction on the dynamic O-ring seal and avoid vacuum loss.
- ◆ Shut down the pump and remove the vacuum hose from the Vacuum Pumping fitting. Then remove the fitting.
  - ◆ Replace the vacuum port cap.
  - ◆ If a heated chamber was used, turn it off and allow it to slowly cool. When the detector reaches ambient temperature, it can be removed and returned to its normal operation location.

## Installing a New Vacuum Seal

### CAUTION

Preventing atmospheric contamination of the vacuum chamber is imperative to the operation and longevity of the detector. Placing the detector inside a plastic bag filled with dry nitrogen gas prior to removing the Vacuum Seal will backfill the detector when the Vacuum Seal is removed and help prevent contamination. *Consult the factory.*

- ◆ Using the 5/16" hex torque wrench, rotate the indium-tipped Vacuum Seal counterclockwise to where the threads completely disengage and then remove it from the vacuum block.
- ◆ Lightly grease the Viton O-ring on the new indium-tipped Vacuum Seal. Use a high-quality grade of vacuum grease such as Apiezon M.
- ◆ Carefully insert the new indium-tipped Vacuum Seal into the corresponding opening on the detector vacuum block to where the threads can be engaged – a turn or two is sufficient. ***Do not rotate the plunger to where it bottoms out. The indium tip should not be disturbed until the new vacuum has been established.***
- ◆ Turn on the pump and follow the Pumping Procedure as outlined on the previous page.